

## Etherbus®

### Industrial Power over Ethernet (PoE) Injectors Pass Power & Data to your Ethernet Field Devices over the same Cable

The EB-PSE-24V-1 or EB-PSE-48V-2 industrial PoE power injectors add 48 VDC power into 1 or 2 Ethernet ports so that you can pass power and data over the same wire to your Ethernet devices in the field. The 24V-1 model steps up and isolates 24 VDC for sourcing 1 PoE port so no separate DC/DC converter is required. The 48V-2 model is two injectors in one to save space and money. Both are ultra-rugged, reliable and easy to use.

#### Product Highlights

- Fully IEEE 802.3af compliant PSE (Power Sourcing Equipment) operation
- Model 1 directly runs off of your existing 24 VDC and powers 1 PoE (48 VDC) port
- Model 2 saves you space and money by powering 2 PoE (48 VDC) ports
- Plug & play saves you time and money
- Truly industrial rated for any application

#### IEEE 802.3af compliant PoE ports

- Power Sourcing Equipment (PSE) operation
- Auto-detection of PD (powered devices)
- Supplies up to 15.4 watts per channel
- Over-temperature and over-current detection
- Over and under-voltage protection

#### True plug and play simplicity

- No user settings
- Ready to use right out of the box

#### SIXNET reliability and long-term support

- Ultra-reliable 1,000,000+ hours MTBF
- 20-year support and service promise

#### Industrial tough – ready for any application

- Truly industrial -40 to 75°C operation (derated)
- Slim package for DIN rail or panel mounting

#### Certified to Perform:



ISO9001  
Certified



European  
Community



Hazardous  
Locations



USA/Canada  
Emissions



Lead & Hazardous  
Substance Free

Single Injector with  
Built-in DC/DC Converter



Dual Injector  
Powers Two Ports

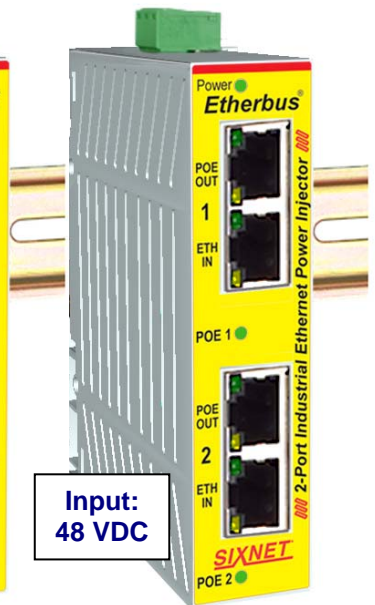

#### Etherbus® Industrial Fieldbus Solutions

Like a true fieldbus, Etherbus® combines all the advantages of Ethernet (speed and openness) with power in the same cable to simplify system wiring, reduce maintenance time and save you money. At the heart of Etherbus are standard Ethernet (802.3) and PoE (802.3af) making it truly open. Etherbus is “Every bus” because it passes any and all Ethernet message packets regardless of origin or protocol. Etherbus works with Modbus/TCP, Profinet, Ethernet/IP, ... (the list is endless). Etherbus works with PoE devices as well as non-PoE devices. It can even deliver standard +24 VDC to your field mounted devices – even non-Ethernet devices. **For more details contact SIXNET for the Etherbus brochure.**

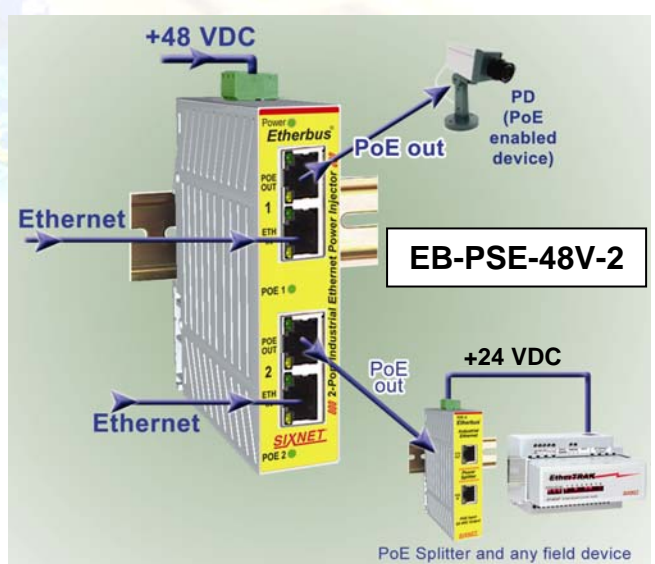

### Performance Specifications

General		Industrial PoE Injectors
Ethernet protocols supported	All IEEE 802.3	
Ethernet connectors per channel	2 (1 for Ethernet in, 1 for PoE out)	
Ethernet port standards	10/100BaseTX IEEE 802.3 / 802.3u	
PoE Output	Fully IEEE 802.3af compliant	
IEEE 802.3af PoE operation	Power Sourcing Equipment (PSE)	
PoE power output	48 VDC @ 15.4 Watts per channel (24V model: Derate 1W per 2°C over 60°C)	
RJ45 PoE pin assignments (A=unused pair; B=signal pair)	A: TX(3,6); RX(1,2); V-(7,8); V+(4,5) B: TX/V- (3, 6); RX/V+ (1, 2)	
PoE operation	Auto-detection & power management	
PoE disconnect mode	AC for 24V-1 and DC for 48V-2	
PoE protection	Over-temp, over-current, over/under-voltage & transient	
Power Input	Fully IEEE 802.3af PoE compliant	
Power input for 48V-2 models	45-56 VDC @ 31 Watts max.	
Power input for 24V-1 models	18-30 VDC @ 20 Watts max.	
PoE transient protection	15,000 watts peak	
PoE spike protection	5,000 watts (10 times for 10 uS)	
Environmental	Truly industrial design	
Operating temperature range	-40 to +75 °C (cold startup @ -40) (24V model: Derate 1W per 2°C over 60°C)	
Storage temperature range	-40 to +85 °C	
Humidity (non-condensing)	5 to 95% RH	
Vibration, shock and freefall	IEC68-2-6, -27 and -32	
Electrical safety		UL508 / CSA C22.2/14 (CUL); EN61010-1
EMC emissions and immunity		FCC Part 15 / ICES-003; EN55022 / IEC61326-1
Hazardous locations		UL1604 / CSA C22.2/213 (CUL), C1, D2; ATEX / Cenelec Zone 2
Mechanical	DIN rail or direct to panel mounting	
Packaging material and protection	Polycarbonate with IP30 protection	
Dimensions (H x W x D)	4 x 1 x 3.3" (10 x 2.5 x 8.3 cm)	
Weight (approximate)	0.17 Kg (0.25 lbs)	
MTBF (estimated)	>1,000,000 hours	

Specifications are subject to change. Consult factory for latest information.

**SIXNET knows industrial** – We have been designing industrial hardware such as Remote Terminal Units for over 25 years and have used this expertise to design the toughest industrial Ethernet products on the market. Don't trust your critical communications to so-called "industrial" hardware from commercial manufacturers. SIXNET products give you proven assurance that your system will keep running for years to come.

### Ordering Guide

<b>EB-PSE-24V-1A</b>	PoE injector for 1 PoE port (uses unused pairs), 24V input
<b>EB-PSE-48V-2A</b>	PoE injector for 2 PoE port (uses unused pairs), 48V input
<b>EB-PSE-24V-1B</b> (Special order)	Special order: uses signal pairs for PoE, ideal for 4 wire cables
<b>EB-PSE-48V-2B</b> (Special order)	Special order: uses signal pairs for PoE, ideal for 4 wire cables
Accessories:	
<b>EB-PS-AC48-75</b>	Industrial power supply, AC to 48 VDC, 75W, 1.5A
<b>EB-PS-AC48-120</b>	Industrial power supply, AC to 48 VDC, 120W, 2.5A
<b>EB-PD-24V-1</b>	PoE splitter for 24VDC devices, 13W (Other voltages available – special order)
<b>EB-CAT5E-##</b>	Kevlar-reinforced Cat5E Ethernet cable and cordsets
<b>EB-RJF-BLKHD-1</b>	IP67 quick-latching (1/4 turn) bulk-head (through-wall) connector
<b>EB-RJF-CAP-1</b>	IP67 protective cap for bulk-head connector
<b>EB-RJF-PLUG-1</b>	IP67 field-installable quick-latching (1/4 turn) Ethernet plug

# SIXNET®

331 Ushers Road, P.O. Box 767 • Clifton Park, NY 12065 USA • +1 (518) 877-5173 • Fax +1 (518) 877-8346

Email: <mailto:sales@sixnetswitch.com> • Web: <http://www.etherbus.com> • Store: <http://www.sixnetstore.com>

For the latest information on all Etherbus products please go to <https://www.etherbus.com>

## Mechanical Dimensions

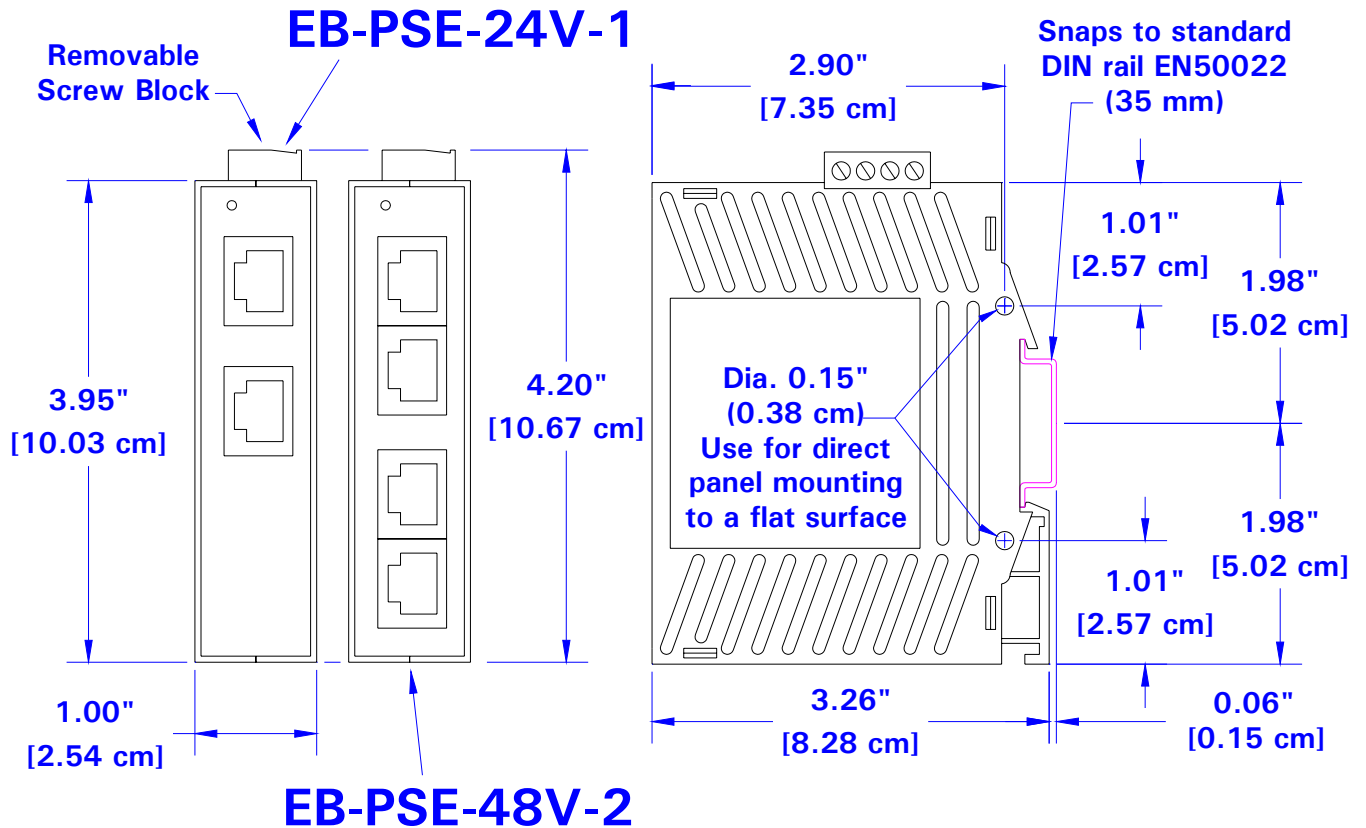

## Power Wiring

### EB-PSE-24V Single DC Power

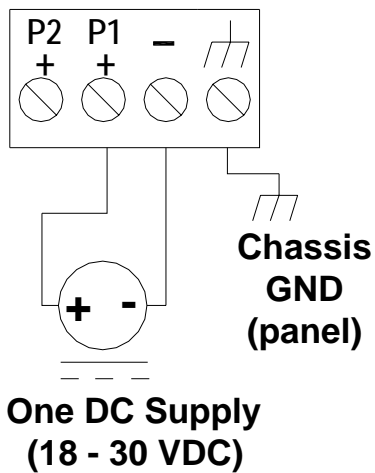

### EB-PSE-24V Dual DC Power

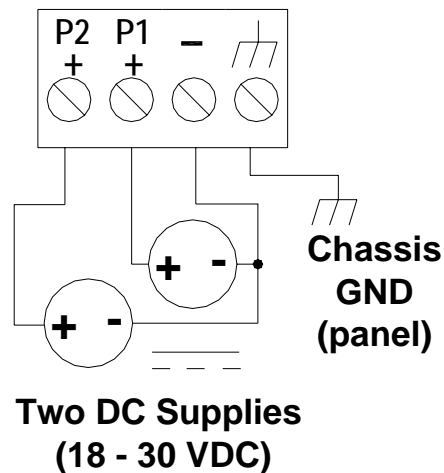

### EB-PSE-48V DC Power Input

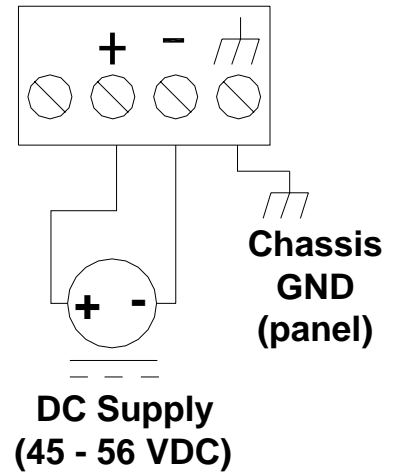

**SIXNET®**

# A Complete Family of Etherbus® Solutions



## Etherbus® Industrial Ethernet PoE Switch

The EB-5ES-PSE combines the ultra-reliability of a five port EtherTRAK Real-time Switch with four industrial PoE sourcing outputs. Simply power this switch with 48 VDC to source the PoE lines. The four PoE ports automatically sense and support both PoE and non-PoE (traditional) Ethernet devices. Or power this switch with 10-30 VDC and it functions as a robust industrial switch that is PoE future-ready. **Check out the separate datasheet for more details.**

## Etherbus® Industrial Power Splitters

These space saving industrial PoE splitters give you all the benefits of Power over Ethernet (PoE) without needing to upgrade your existing non-PoE Ethernet devices. These splitters generate isolated 24 VDC power for your non-PoE or even non-Ethernet devices. Think of this splitter as an industrial 24 VDC power supply that is powered by your incoming PoE (Etherbus) cable. The Ethernet output can be connected to any traditional (non-PoE) Ethernet device. **Check out the separate datasheet for more details.**



## Etherbus® Industrial Ethernet Cabling

The trademarked Etherbus® cable is the toughest Ethernet cable in the world. Ensure the reliability of your industrial Ethernet systems (indoors or outdoors) with this ultra-rugged Kevlar-reinforced Etherbus cable. This Cat 5E cable is double shielded for best noise immunity and has excellent temperature, UV, hydrolysis and microbial resistance. You can install it anywhere with confidence that it will keep working for the long haul. **Check out the separate datasheet for more details.**



## Etherbus® Industrial Ethernet Connectors

Etherbus features the Amphenol RJField reverse-bayonet quick latching (1/4 turn) connector system. These IP67 rated connectors and plugs are water and corrosion proof. The bulk-head connector allows you to interface between standard Ethernet wiring inside a cabinet to industrial cabling outside. The mating plugs can be easily field installed around an existing Ethernet cable without the need for tools. **Check out the separate datasheet for more details.**



## Etherbus® Industrial Power Supplies

SIXNET offers several industrial power supplies to meet your PoE, 24 VDC or 48 VDC power needs. AC to 48 VDC models are available with up to 120 Watts or more. Plus a 48 VDC to 24 VDC compact unit gives you 15 watts of power. This supply is ideal for powering industrial equipment from the 48 VDC power sources found in telecommunication or Etherbus systems. **Check out the separate datasheet for more details.**



**Request Your  
FREE Product CD at  
<http://www.etherbus.com>**



# SIXNET®

331 Ushers Road, P.O. Box 767 • Clifton Park, NY 12065 USA • +1 (518) 877-5173 • Fax +1 (518) 877-8346  
Email: <mailto:sales@sixnetswitch.com> • Web: <http://www.etherbus.com> • Store: <http://www.sixnetstore.com>